



Installation procedures

Wall protections & handrails

Spm[®]
wall protection

INSTALLING HANDRAILS

1. TOOLS REQUIRED	33
2. METHODS FOR FIXING HANDRAILS	33
3. INSTALLATION PROCEDURE	33/35
3.1 Measuring and cutting aluminium and PVC profiles to length.....	34
3.2 Cutting aluminium and PVC lengths and cutting to measure accessories.....	35
3.3 Fixing handrails on DECOCHOC panels.....	35
4. ESCORT HANDRAILS	35/39
4.1 Presentation of the different brackets available for ESCORT handrails	35
4.2 Presentation and assembly of the different accessories for ESCORT handrails.....	36
4.3 Preparing ESCORT handrails.....	39
4.4 Fixing ESCORT handrails	39
5. LINEA'TOUCH AND TOUCH+ HANDRAILS	41/43
5.1 Presentation and assembly of the different accessories for LINEA'TOUCH and TOUCH+ handrails	41
5.2 Preparing LINEA'TOUCH and TOUCH+ handrails	42
5.3 Fixing LINEA'TOUCH and TOUCH+ handrails.....	43
6. STARLINE HANDRAILS	45/47
6.1 Presentation and assembly of the different accessories for STARLINE handrails.....	45
6.2 Preparing STARLINE handrails.....	46
6.3 Fixing STARLINE handrails	47
7. ESCORT'DUO AND LINEA'DUO HANDRAILS	48/49
7.1 Presentation and assembly of the different accessories for ESCORT'DUO and LINEA'DUO handrails.....	48
7.2 Preparing ESCORT'DUO and LINEA'DUO handrails	48
7.3 Fixing ESCORT'DUO and LINEA'DUO handrails.....	49
8. PERFORMER 2 HANDRAILS	51/53
8.1 Presentation and assembly of the different accessories for PERFORMER 2 handrails.....	51
8.2 Preparing PERFORMER 2 handrails.....	51
8.3 Fixing PERFORMER 2 handrails	53
9. INTERNAL, EXTERNAL AND MADE-TO-MEASURE ANGLE PIECES	55
10. ADJUSTMENT SHIM FOR ESCORT, STARLINE, LINEA'TOUCH AND TOUCH+ HANDRAILS	56
11. INSTALLING HANDRAILS WITH THE SERVICE DUCT KIT	56
12. INSTALLING CURVED HANDRAILS	59
13. MAINTENANCE	59

1. TOOLS REQUIRED

- Sliding mitre saw and carbide blade for aluminium/PVC
E.g. FESTOOL KS 88E saw – Blade reference TF52
- Measuring tape and pencil
Reference: ROMUS 93290 and 93185
- Electric drill and screwdriver
- Angle finder
Reference: ROMUS 93230
- Rigid PVC glue, such as TANGIT - U
- Pop rivets or 3 mm self-tapping screws
- Rivet gun
- 2 mm, 2.5 mm and 3 mm Allen keys
- Laser level



2. METHODS FOR FIXING HANDRAILS

The table below shows the recommended fixing techniques to be used for the main types of wall surface found in the building industry.

These techniques apply to all SPM handrails.

TYPE OF WALL	FIXING PROCEDURE
WALLS WITH WOODEN STUDS	Woodscrews, 6 mm
METALLIC STRUCTURES	Self-tapping screws, 6 mm
PLASTERBOARD (SINGLE SKIN), HOLLOW BRICK, HOLLOW BREEZE BLOCK*	Metal expansion plugs, 6 mm
PLASTERBOARD (DOUBLE SKIN)	Metal expansion plugs, 6 mm
CONCRETE WALLS	FISCHER-type plugs, 8 mm diameter for 6 mm screws
SOLID BRICK AND OLD WALLS	FISCHER-type plugs, 8 mm diameter for 6 mm screws
HOLLOW PLASTER TILES, CELLULAR CONCRETE	FISCHER-type plugs, 8 mm diameter for 6 mm screws

[*] If the area is subject to heavy traffic, add an extra wood or metal stud in the partition to withstand a vertical and horizontal pressure level of 100 kg between two brackets. If installing the handrail on a single-skin plasterboard wall (such as Gypsum), add wood or metal reinforcements according to the supplier's recommendations. With ESCORT, LINEA'TOUCH and STARLINE handrails, use countersinking screws. With PERFORMER 2, ESCORT'DUO and LINEA'DUO handrails, use flange head screws (flat head) with a 12 mm flange diameter.

3. INSTALLATION PROCEDURE

The procedure below describes the quickest and easiest way to install SPM handrails. In principle, there are two major stages:

- Measure and cut the profiles to length
- Prepare and fix the handrails

The first stage is common to all SPM handrail models.

The second stage is specific to each handrail model.

INSTALLING HANDRAILS

3.1 MEASURING AND CUTTING ALUMINIUM AND PVC PROFILES TO LENGTH

- Measure each section of wall in order to cut and prepare the lengths of handrail before installation.
- At each end of the handrail, allow a clearance of at least 30 mm between the end of the handrail (with its wall return) and the edge of the wall or door frame. This clearance allows the wall return to be removed if it has to be replaced.

Example of measuring a straight wall section:

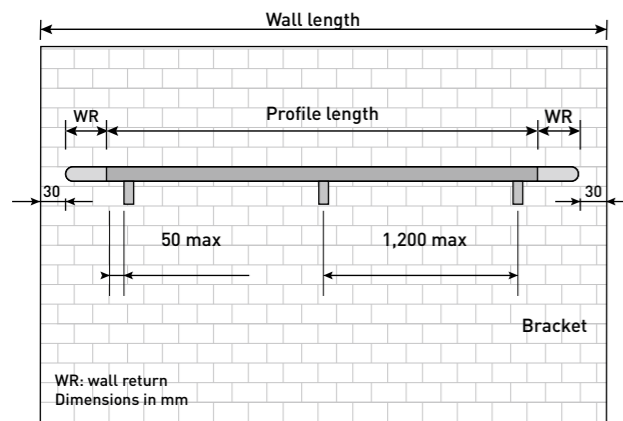

Example of measuring a wall with an internal / external angle:

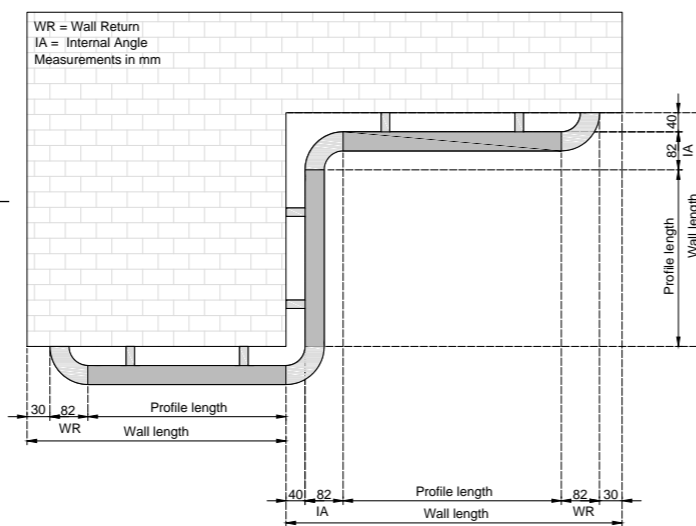

Based on the measurement of the wall after subtracting the necessary clearance of 30 mm on the side(s), use the table below to calculate the cutting lengths of the aluminium and PVC profiles based on the various wall returns and internal / external angle pieces used:

HANDRAIL	ENDCAP	FLAT ENDCAP	BEVELLED ENDCAP	WALL RETURN	EXTENDED AND CURVED WALL RETURN	INTERNAL / EXTERNAL ANGLE PIECE
ESCORT	PVC & Alu: - 22 mm	PVC & Alu: - 4 mm	-	PVC & Alu: - 82 mm	-	PVC & Alu: Internal: - 122 mm External: - 2 mm
STARLINE	PVC & Alu: - 17 mm	-	-	PVC & Alu: - 85 mm	-	PVC & Alu: Internal: - 132 mm External: - 2 mm
PERFORMER 2	PVC: - 7 mm Alu: - 16 mm	-	-	PVC: - 106 mm Alu: - 86 mm	-	External PVC: + 3 mm External Alu: + 23 mm
LINEA TOUCH AND TOUCH+	PVC & Alu: - 12 mm	-	PVC & Alu: - 25 mm	PVC & Alu: - 82 mm	PVC & Alu: - 188 mm	PVC & Alu: Internal: - 122 mm External: 0 mm
ESCORT DUO LINEA DUO	PVC: - 27 mm Alu: - 35 mm	-	-	PVC: - 97 mm Alu: - 105 mm	-	Internal PVC: - 144.5 mm External Alu: - 152.5 mm External: - 2 mm

(the values include the dimensions of the joints)

INSTALLING HANDRAILS

3.2 CUTTING ALUMINIUM AND PVC LENGTHS AND CUTTING TO MEASURE ACCESSORIES

- Once the lengths of the aluminium and PVC profiles have been calculated, cut the profiles to length using a mitre saw and a suitable blade (preferably a fine-toothed blade in order to avoid splinters). Recommended blades feature alternating flat teeth and trapezoidal teeth. Refer to "Tools Required".



- For a better finish, saw the aluminium and PVC profiles to length while they are snap-fixed together and held from one side. Preferably cut while pushing the sliding saw.
- Made-to-measure angle pieces can be cut with a mitre saw. Mount the angle piece onto a section of profile to hold it steady while cutting and thereby maximise safety.
- Make sure that you position the angle piece correctly to cut it "on the radius". A slightly oblique cut will cause mounting problems by altering the dimensions of the contact surfaces.

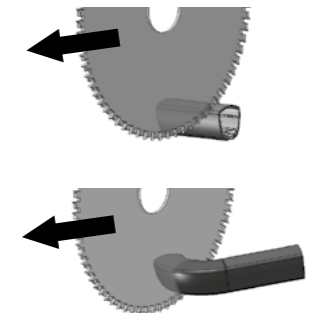

3.3 FIXING HANDRAILS ON DECOCHOC PANELS

- Handrail brackets can only be fixed to DECOCHOC panels where temperature conditions are perfectly stable (otherwise the brackets could prevent the panels from expanding, causing them to come away from the wall).

4. ESCORT HANDRAILS

4.1 PRESENTATION OF THE DIFFERENT BRACKETS AVAILABLE FOR ESCORT HANDRAILS

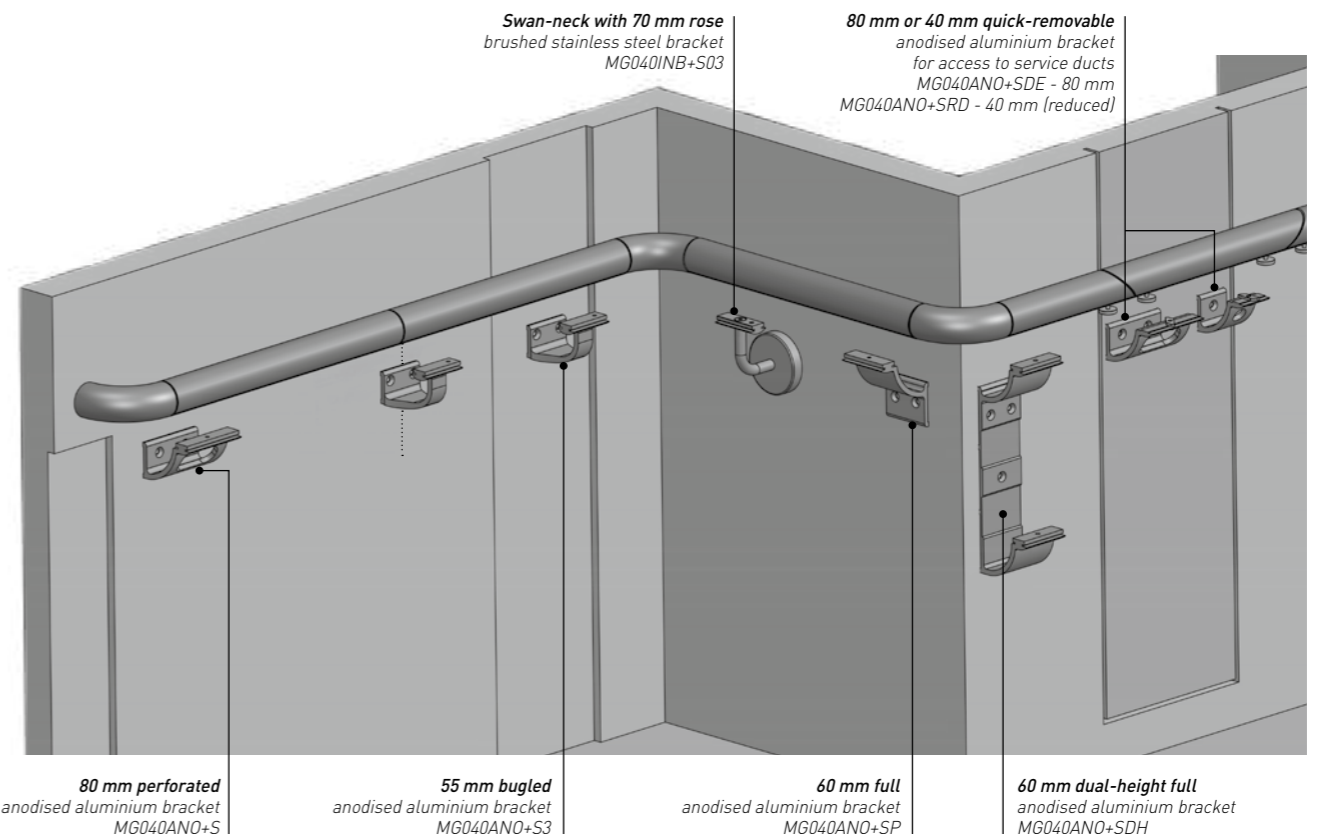

INSTALLING ESCORT

4.2 PRESENTATION AND ASSEMBLY OF THE DIFFERENT ACCESSORIES FOR ESCORT HANDRAILS

Joining piece for straight lengths

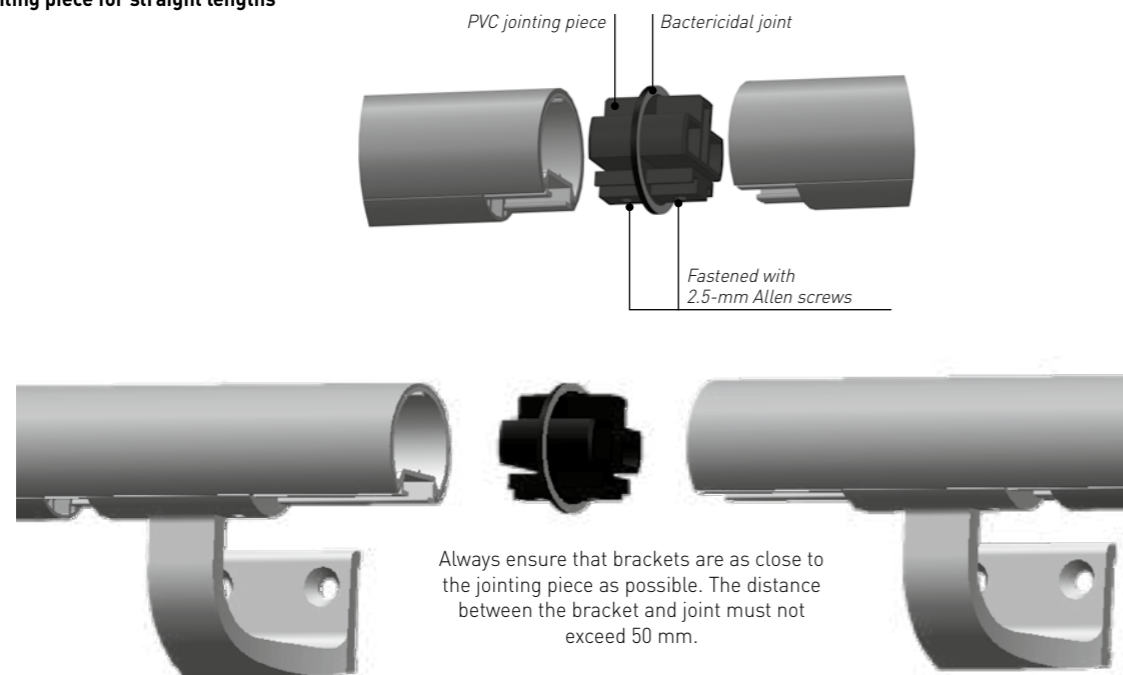

Joining internal / external angle pieces with straight lengths

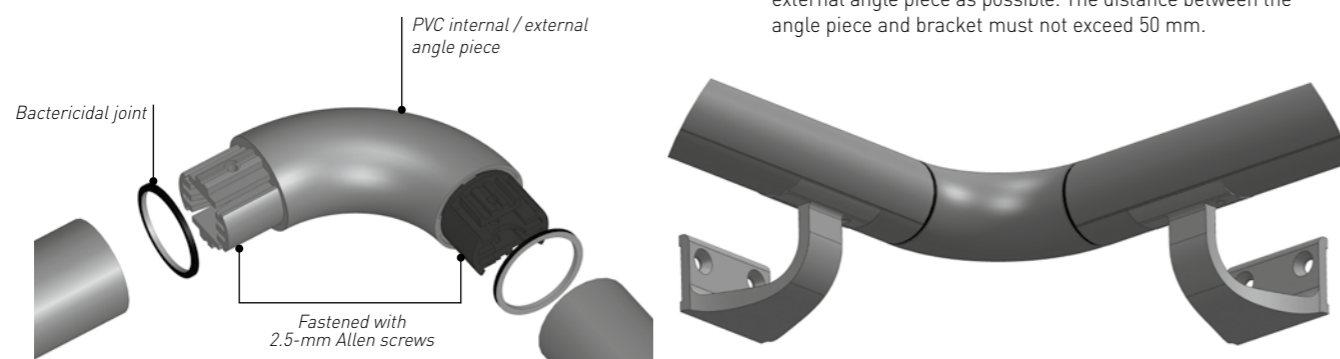

Joining made-to-measure angle pieces with straight lengths

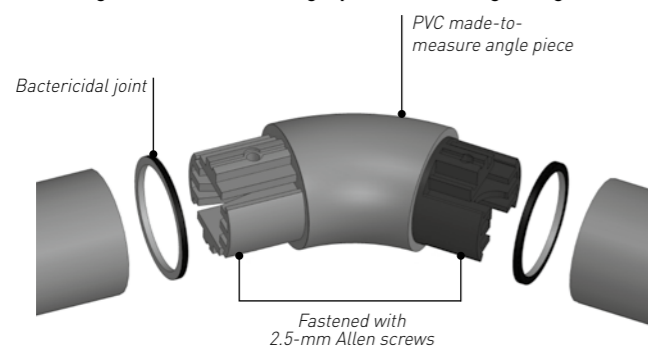

INSTALLING ESCORT

Joining endcaps / flat endcaps and wall returns with straight lengths

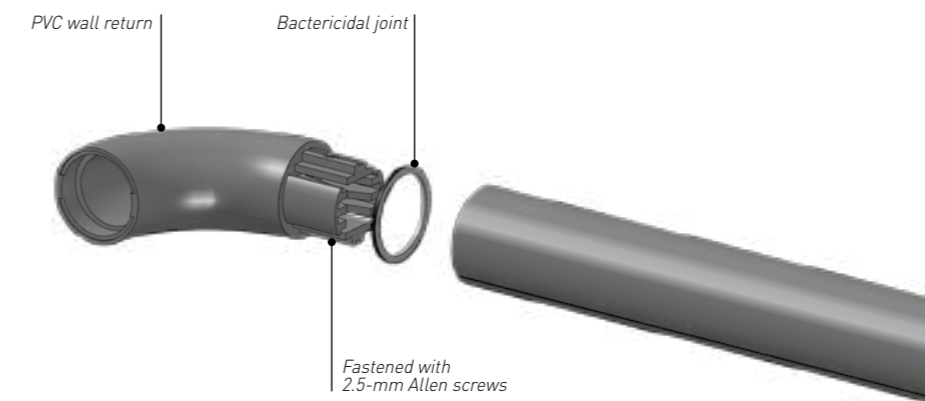
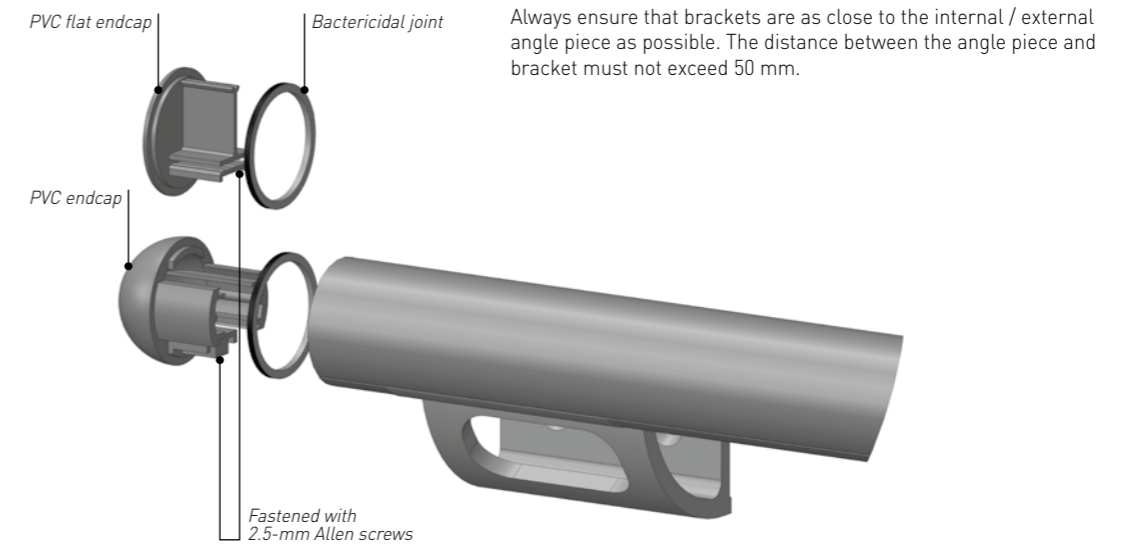

Fitting blanking plugs

Blanking plugs are used in sectors with stringent hygiene requirements and provide a bactericidal finish for wall returns.



INSTALLING ESCORT

Fitting support washers (optional)

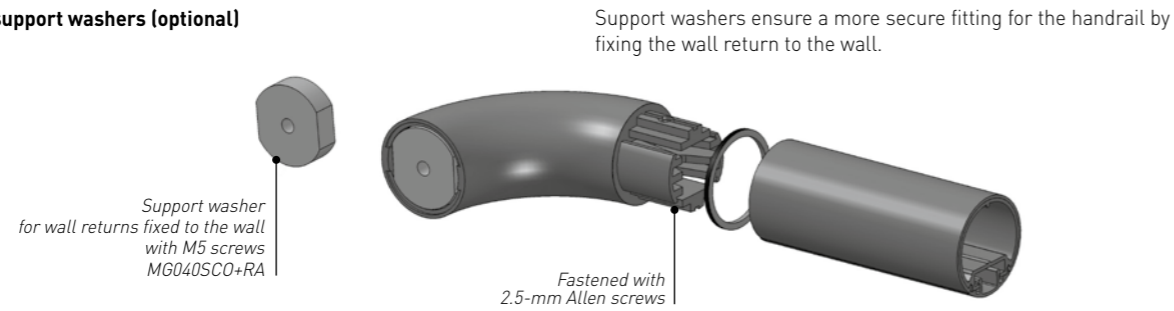

Fitting slope links / angled slope links and Rapid'Angle (for staircases)

Always ensure that brackets are as close to the internal / external angle piece as possible. The distance between the angle piece and bracket must not exceed 50 mm.

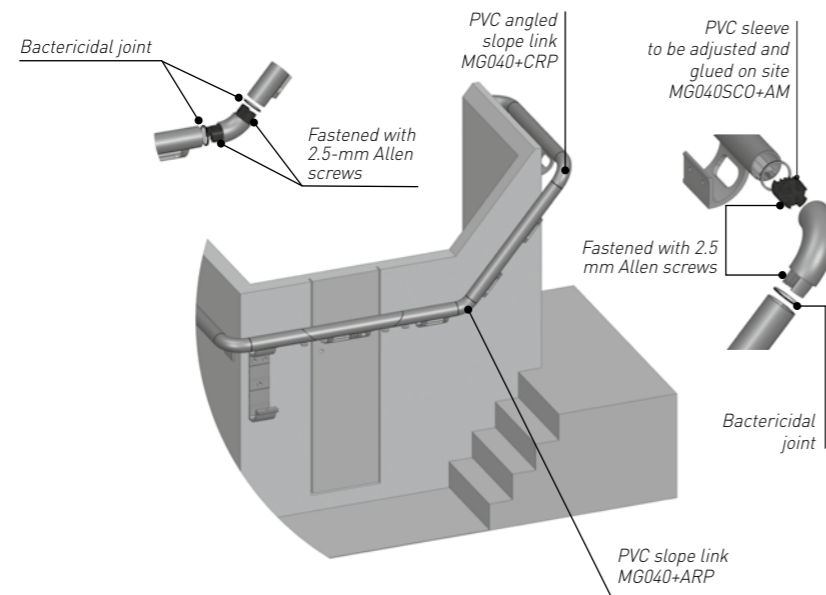

Always ensure that brackets are as close to the angle pieces as possible. The distance between the angle piece and bracket must not exceed 50 mm.

Rapid'Angle: adapts to every angle between 80 and 180° without exception

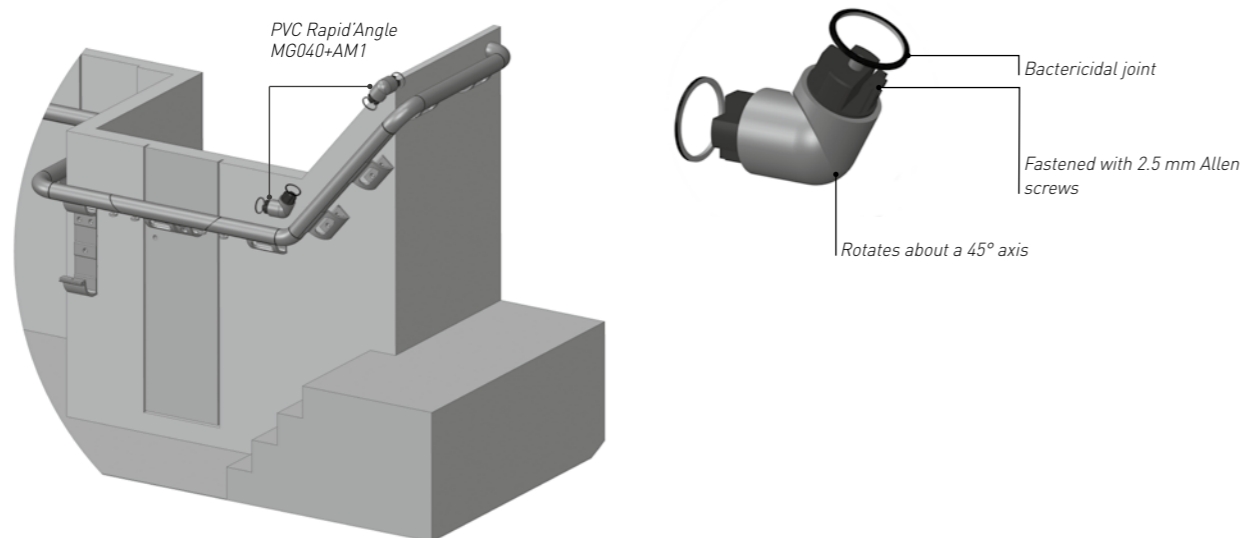

INSTALLING ESCORT

4.3 PREPARING ESCORT HANDRAILS

Refer to Sections 3.1 and 3.2 on how to calculate the cutting lengths for the profiles. Once the profiles have been cut to length:

- Slide the brackets into the groove of the aluminium profile.

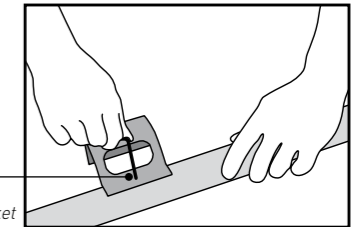
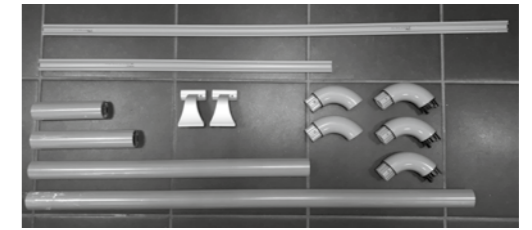

- Position the end brackets at no more than 50 mm from the end of the profile.
- Set the brackets at maximum intervals of 1,200 mm.
- For short handrail lengths, use at least two brackets at even intervals.
- Fix the brackets to the aluminium profile using a 2.5 mm Allen key.
- Then insert the accessories (endcaps, wall returns, jointing pieces, etc.) into the profile and secure with the pre-fitted screws until they are flush and hold the accessory in place.
- Finally, cut the closer to the required lengths and clip into the profile groove.

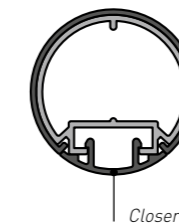

4.4 FIXING ESCORT HANDRAILS

- Once the handrail lengths have been prepared, together with their endcaps, wall returns, brackets and closers, mount them to their respective wall sections.
- For a handrail height of 900 mm from the floor, use a pencil (or laser) to draw a mark at the required height. The table below shows the drilling heights according to the ESCORT brackets used:

TYPE OF BRACKET	POSITION OF THE MARK FOR A HANDRAIL HEIGHT AT 900 M
80 mm perforated bracket MG040ANO+S	845 mm
55 mm bugled bracket MG040ANO+S3	845 mm
60 mm full bracket MG040ANO+SP	810 mm
55 mm bugled bracket MG040ANO+S3C	845 mm
60 mm dual-height full bracket MG040ANO+SDH	800 mm - 725 mm
80 mm quick-removable perforated bracket MG040ANO+SDE	845 mm
40 mm quick-removable reduced bracket MG040ANO+SDR	845 mm
Swan-neck with 70 mm rose MG040INB+S03	821 mm - 786 mm

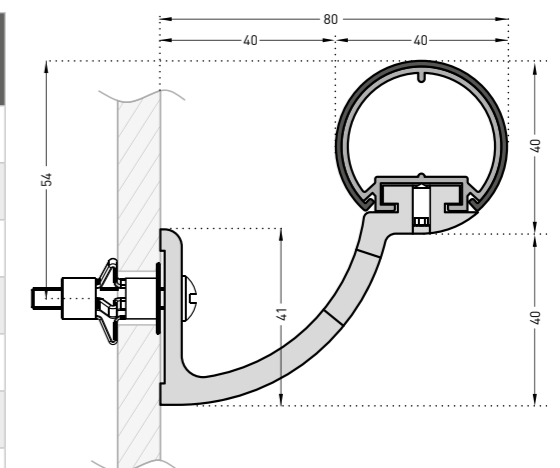

80 mm perforated bracket MG040ANO+S

- Hold the handrail against the wall, leaving a space of 30 mm from the edge of the wall, and place the holes drilled in the brackets over the marks.
- Position the first bracket for each end as close as possible to each finishing accessory (the first bracket should be no more than 50 mm from the finishing accessory).
- Each handrail must be mounted to the wall with at least two brackets.
- If several brackets need to be installed, space them at intervals of no more than 1,200 mm (800 mm intervals in heavy-traffic areas or on lighter wall surfaces, such as plasterboard).
- Use a spirit level to check that the handrail is horizontal and then mark the holes to be drilled for each bracket on the wall.
- Now use a suitable drill bit to drill into the wall. The diameter of the drilled hole may vary according to the type of wall (refer to the methods for installing handrails in Section 2).
- When drilling in clean environments, you are advised to use an extractor system connected to the drill to effectively collect all the dust.
- Once all the holes have been drilled, fix the handrail brackets to the wall, starting with the two end brackets.

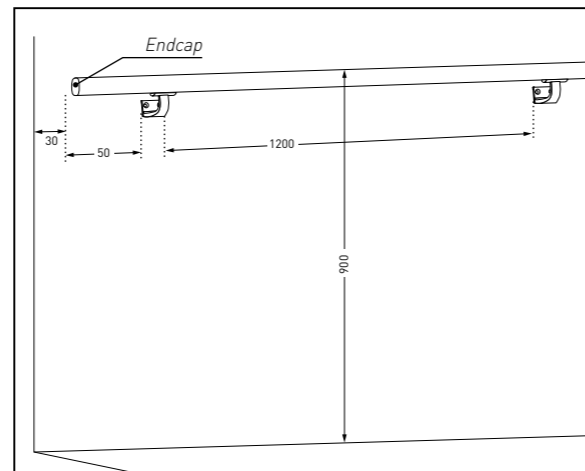

Access to
LINEA'TOUCH
handrail
installation video

5. LINEA'TOUCH AND TOUCH+ HANDRAILS

5.1 PRESENTATION AND ASSEMBLY OF THE DIFFERENT ACCESSORIES FOR LINEA'TOUCH AND TOUCH+ HANDRAILS

Presentation

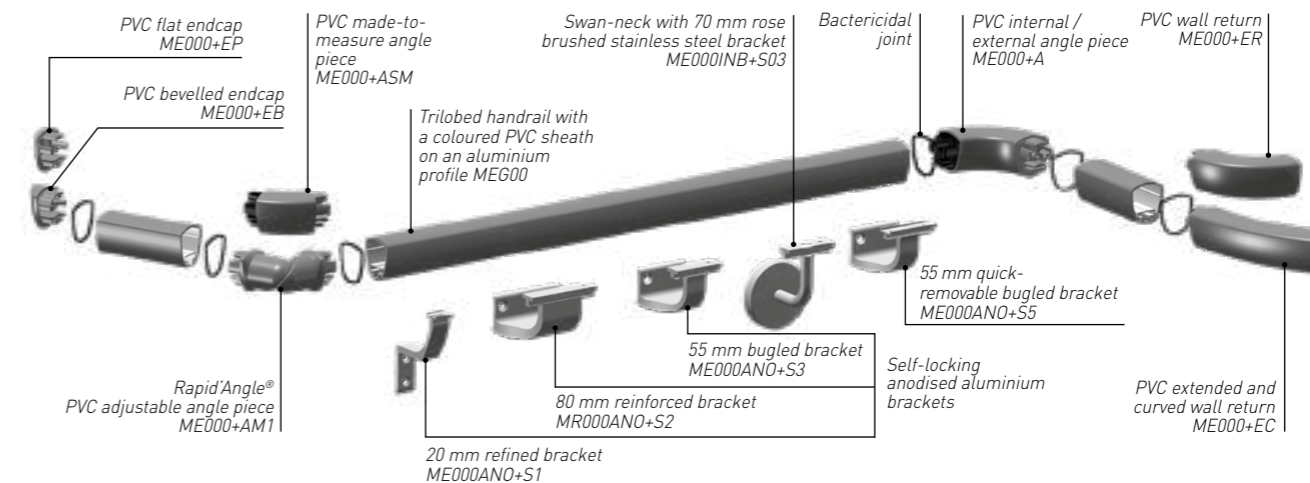

Joining wall returns with straight lengths

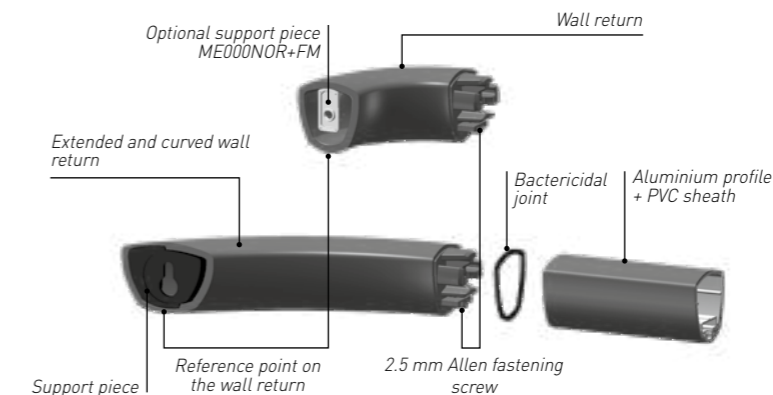

- Extended and curved wall returns must be fitted with wall-mounted support pieces.
- Once the wall return has been assembled and the handrail fixed, use the mark beneath the wall return as a reference point for drilling the hole. Once the mark has been pencilled on the wall, remove the wall return from the handrail and mark a point 22 mm vertically above the reference point as the centre for the hole to be drilled.
- Drill, plug and screw the support piece to the wall. Place the wall return on the support piece and then reassemble with the handrail.
- The support piece is always supplied with extended and curved wall returns. It is available as an optional extra with standard wall returns (the procedure is the same, regardless of the wall return used).

Joining endcaps with straight lengths

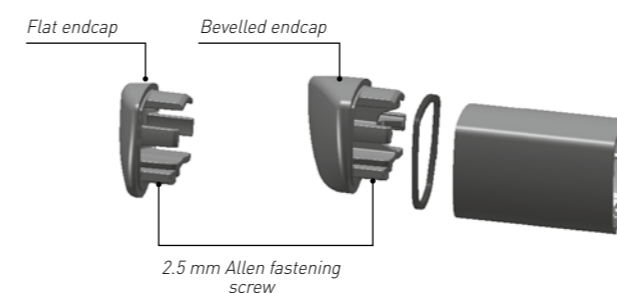

Joining straight lengths

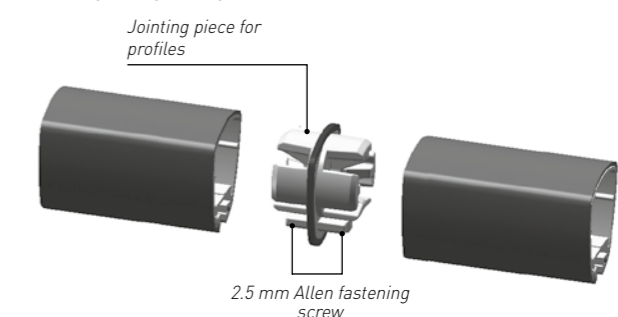



INSTALLING LINEA'TOUCH AND TOUCH+

Joining angle pieces with straight lengths

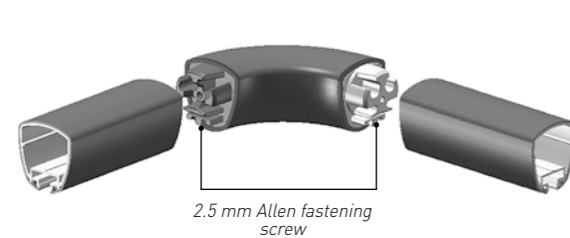

Joining made-to-measure angle pieces with straight lengths

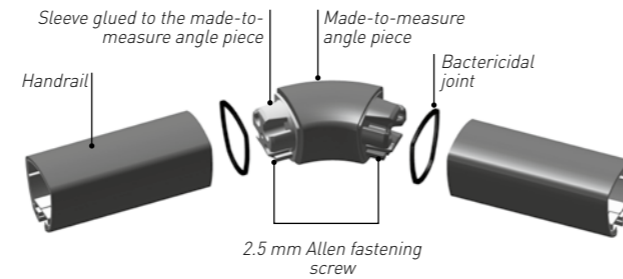

5.2 PREPARING LINEA'TOUCH AND TOUCH+ HANDRAILS

Refer to Sections 3.1 and 3.2 on how to calculate the cutting lengths for the profiles.

Once the profiles have been cut to length:

- Slide the brackets into the groove of the aluminium profile.
- Position the end brackets at no more than 50 mm from the end of the profile.
- Set the brackets at maximum intervals of 1,200 mm.
- For short handrail lengths, use at least two brackets at even intervals.
- Fix the brackets to the aluminium profile using a 2.5 mm Allen key.
- Then insert the accessories (endcaps, wall returns, jointing pieces, etc.) into the profile and secure with the pre-fitted screws until they are flush and hold the accessory in place.

LINEA'TOUCH

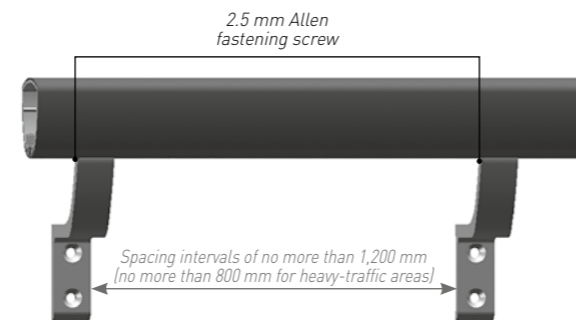
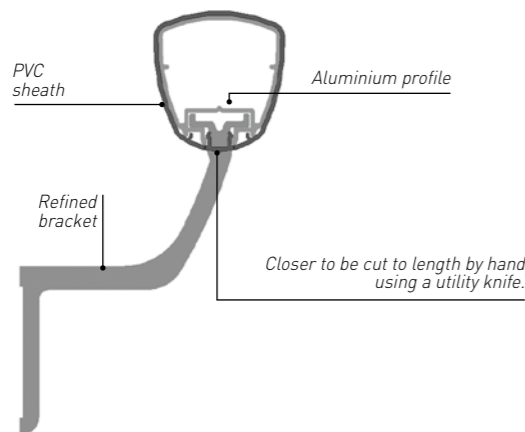

LINEA'TOUCH+

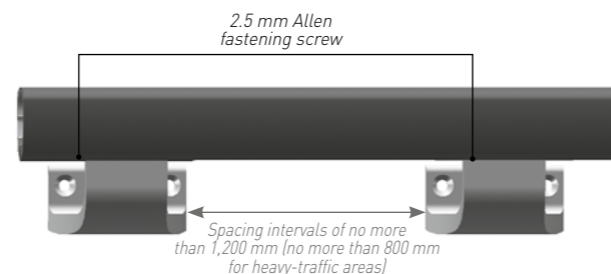
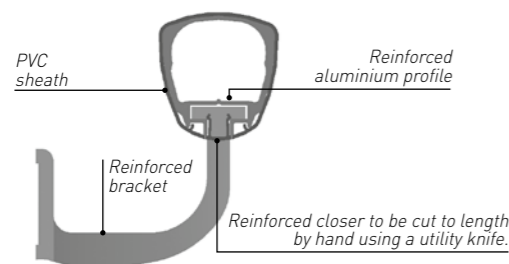

INSTALLING LINEA'TOUCH AND TOUCH+

- Finally, cut the closer to the required lengths and clip into the profile groove.
- If the closer is positioned at the end against a wall return, angle piece or jointing piece, it will need to be trimmed to reduce its height. Using a utility knife, cut the closer over a length of 15 mm.

5.3 FIXING LINEA'TOUCH AND TOUCH+ HANDRAILS

LINEA'TOUCH

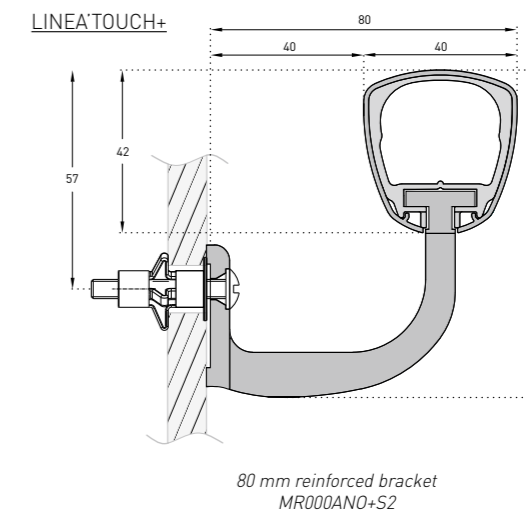
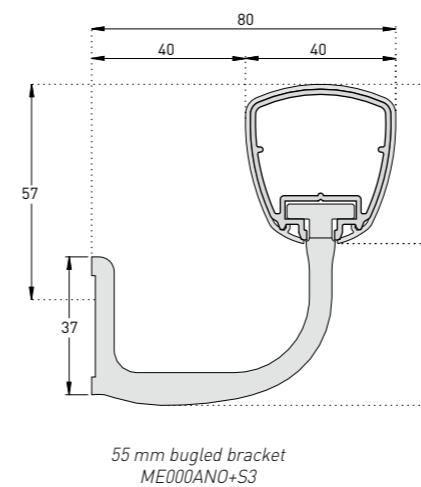
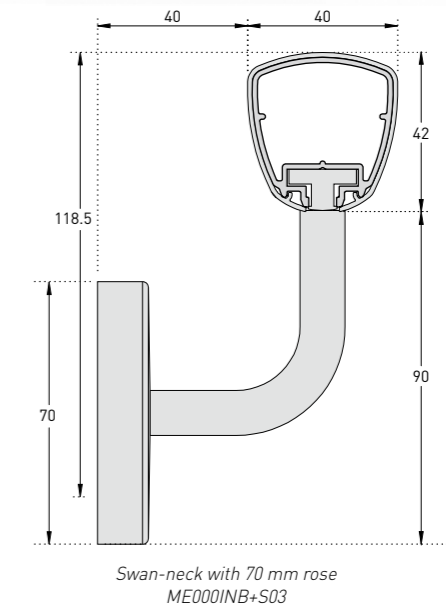
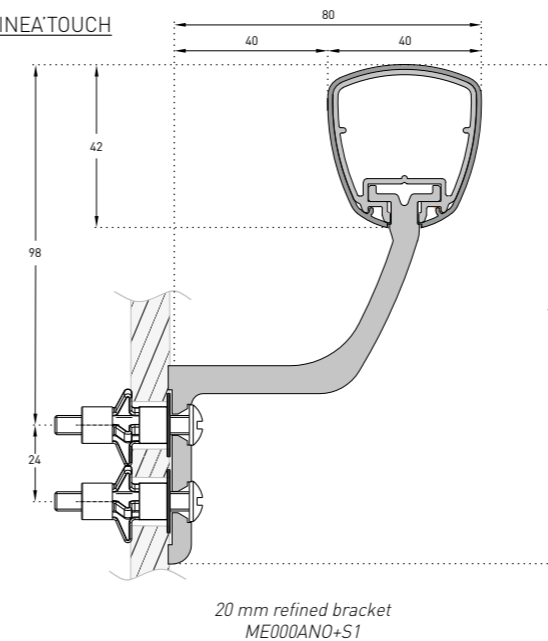

For a handrail height of 900 mm:

TYPE OF BRACKET	POSITION OF THE MARK FOR A HANDRAIL HEIGHT AT 900 MM
20 mm refined bracket ME000ANO+S1	802 mm - 778 mm
80 mm reinforced bracket MR000ANO+S2	843 mm
55 mm bugled bracket ME000ANO+S3	843 mm
Swan-neck with 70 mm rose ME000INB+S03	816.5 mm - 781.5 mm
55 mm quick-removable bugled bracket ME000ANO+S5	843 mm

INSTALLING LINEA'TOUCH AND TOUCH+

- Hold the handrail against the wall, leaving a space of 30 mm from the edge of the wall, and place the holes drilled in the brackets over the marks.

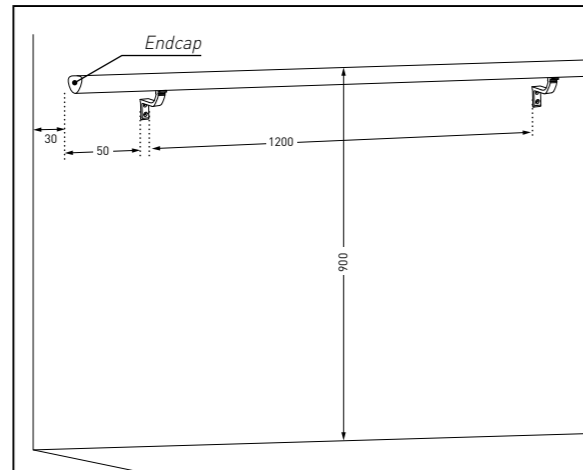

- Position the first bracket for each end as close as possible to each finishing accessory (the first bracket should be no more than 50 mm from the finishing accessory).
- Each handrail must be mounted to the wall with at least two brackets.
- If several brackets need to be installed, space them at intervals of no more than 1,200 mm (800 mm intervals in heavy-traffic areas or on lighter wall surfaces, such as plasterboard).
- Use a spirit level to check that the handrail is horizontal and then mark the holes to be drilled for each bracket on the wall.
- Now use a suitable drill bit to drill into the wall. The diameter of the drilled hole may vary according to the type of wall (refer to the methods for installing handrails in Section 2).
- When drilling in clean environments, you are advised to use an extractor system connected to the drill to effectively collect all the dust.
- Once all the holes have been drilled, fix the handrail brackets to the wall, starting with the two end brackets.

INSTALLING STARLINE

6. STARLINE HANDRAILS

6.1 PRESENTATION AND ASSEMBLY OF THE DIFFERENT ACCESSORIES FOR STARLINE HANDRAILS

Presentation

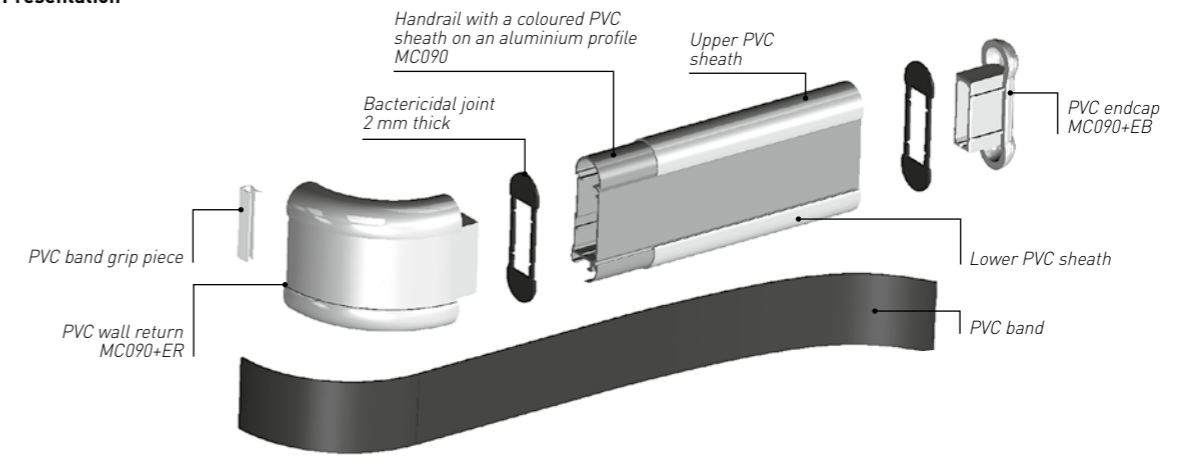

Self-locking anodised aluminium brackets

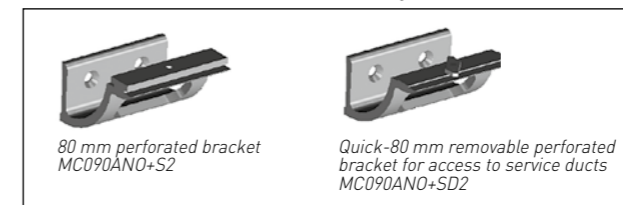

Joining made-to-measure angle pieces to straight lengths

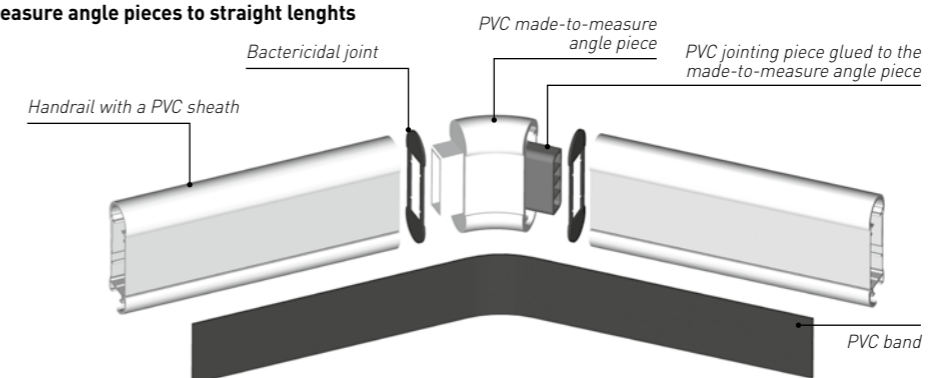

Joining straight lengths

Jointing pieces are used to maintain stability and ensure a continuous geometric finish between two straight handrail lengths.

STARLINE jointing pieces comprise two parts that are quick and easy to fit:

- A 100 mm-long assembly wedge for joining handrails.
- A jointing piece for aligning handrail lengths.

In case of a STARLINE handrail with a PVC sheath, offset the ends of the aluminium profiles and PVC sheaths to conceal any clearances.

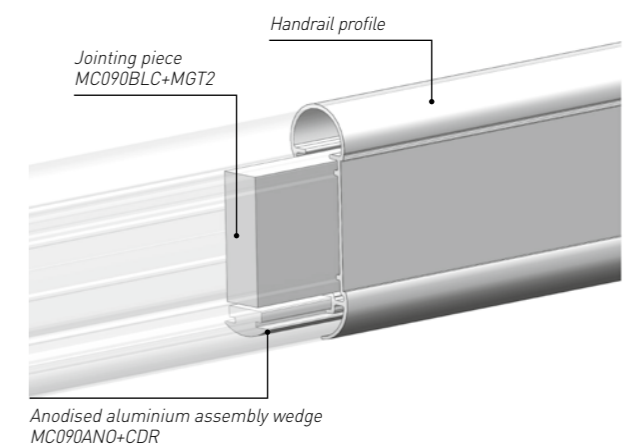

INSTALLING STARLINE

6.2 PREPARING STARLINE HANDRAILS

Refer to Sections 3.1 and 3.2 on how to calculate the cutting lengths for the profiles. Once the profiles have been cut to length:

- Slide the brackets into the groove of the aluminium profile.
- Position the end brackets at no more than 50 mm from the end of the profile.
- Set the brackets at maximum intervals of 1,200 mm.
- For short handrail lengths, use at least two brackets at even intervals.
- Fix the brackets to the aluminium profile using a 2.5 mm Allen key.
- Then insert the accessories (endcaps, wall returns, jointing pieces, etc.) into the profile and secure with the pre-fitted screws until they are flush and hold the accessory in place.
- Assemble the profile and accessories using a self-tapping screw or 3 mm diameter rivet.

Position the screw or rivet 10 mm from the end.

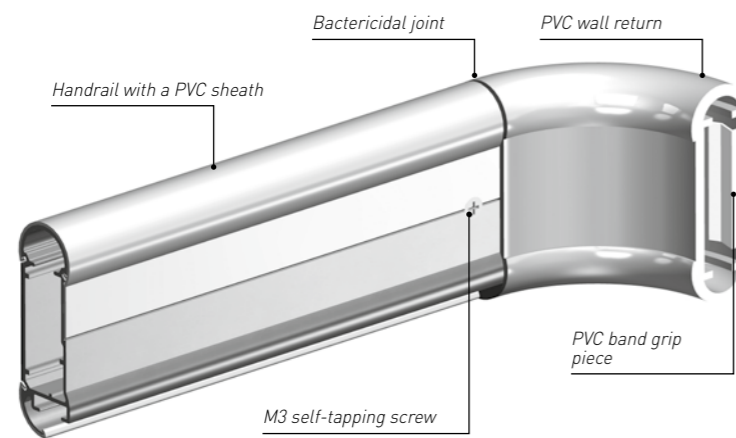

- For anodised and PVC sheathed STARLINE handrails, fix the flexible adhesived PVC band along the whole length of the profile and accessories. A band grip piece must be used to secure the band at the end of the accessory.
- Press down hard (with a roller) all along the length.

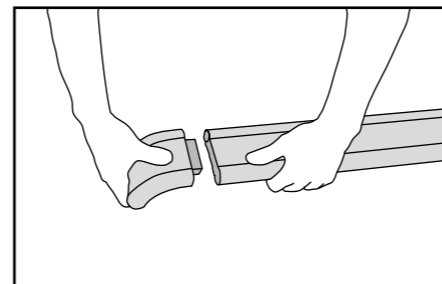
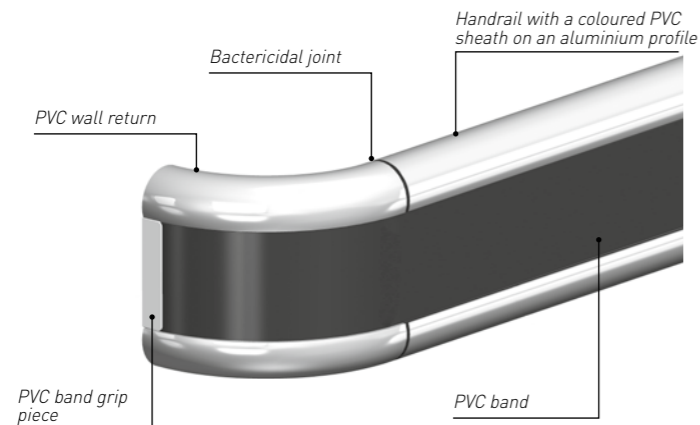

INSTALLING STARLINE

6.3 FIXING STARLINE HANDRAILS

- Once the handrail lengths have been prepared, together with their wall returns and brackets, fix them to their respective wall sections.
- For a handrail height of 900 mm from the floor, use a pencil (or laser) to draw a mark at the required height. The table opposite shows the drilling heights according to the STARLINE brackets used:

TYPE OF BRACKET	POSITION OF THE MARK FOR A HANDRAIL HEIGHT AT 900 MM
80 mm perforated bracket MC090ANO+S2	800 mm
80 mm quick-removable perforated bracket MC090ANO+SD2	800 mm

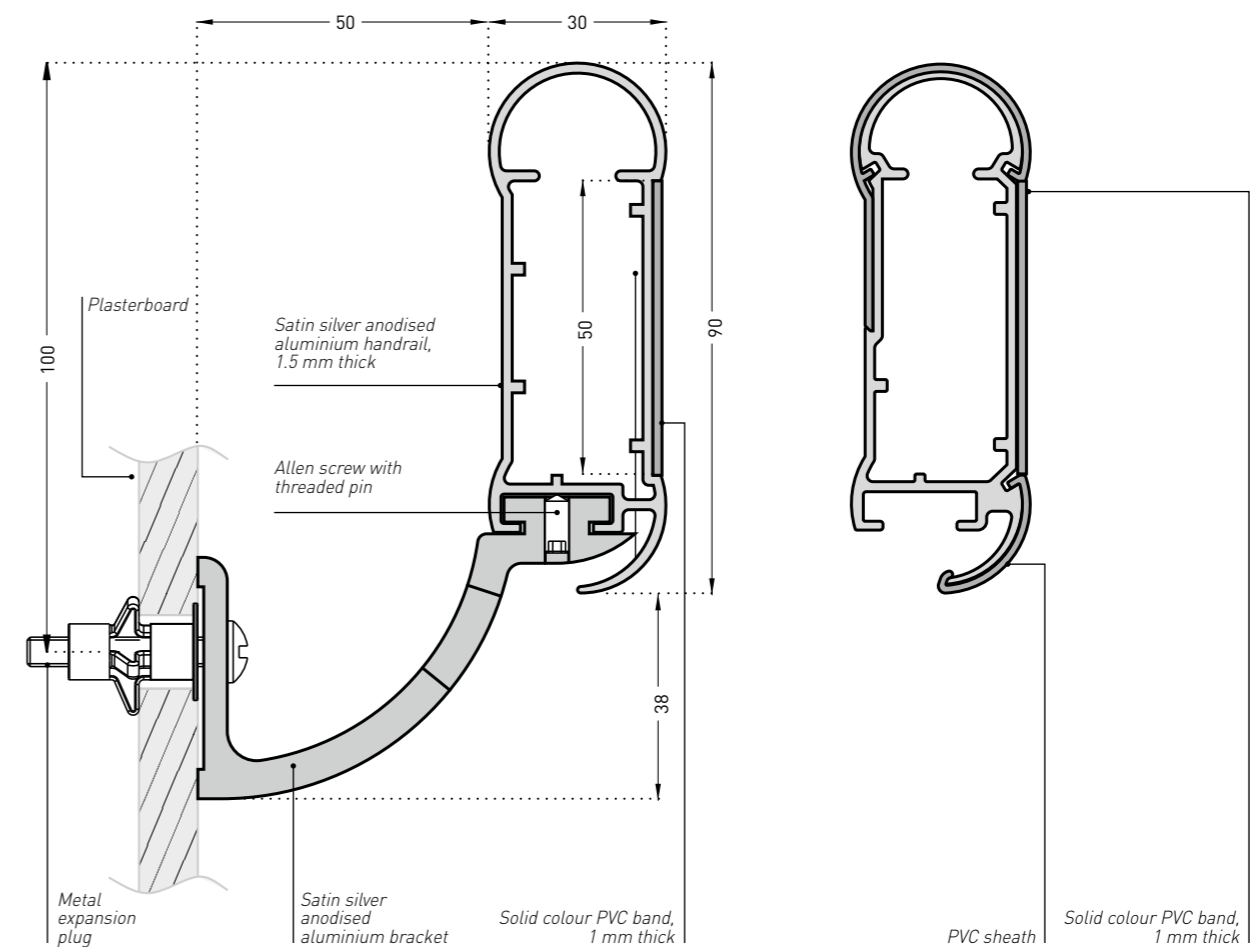

- Once each wall section has been marked out, fix the handrail to the wall using the method shown for ESCORT handrails (Section 4.4).

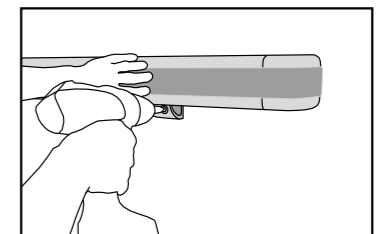

INSTALLING ESCORT'DUO AND LINEA'DUO

INSTALLING ESCORT'DUO AND LINEA'DUO

7. ESCORT'DUO AND LINEA'DUO HANDRAILS

7.1 PRESENTATION AND ASSEMBLY OF THE DIFFERENT ACCESSORIES FOR ESCORT'DUO AND LINEA'DUO HANDRAILS

Presentation

ESCORT'DUO

LINEA'DUO

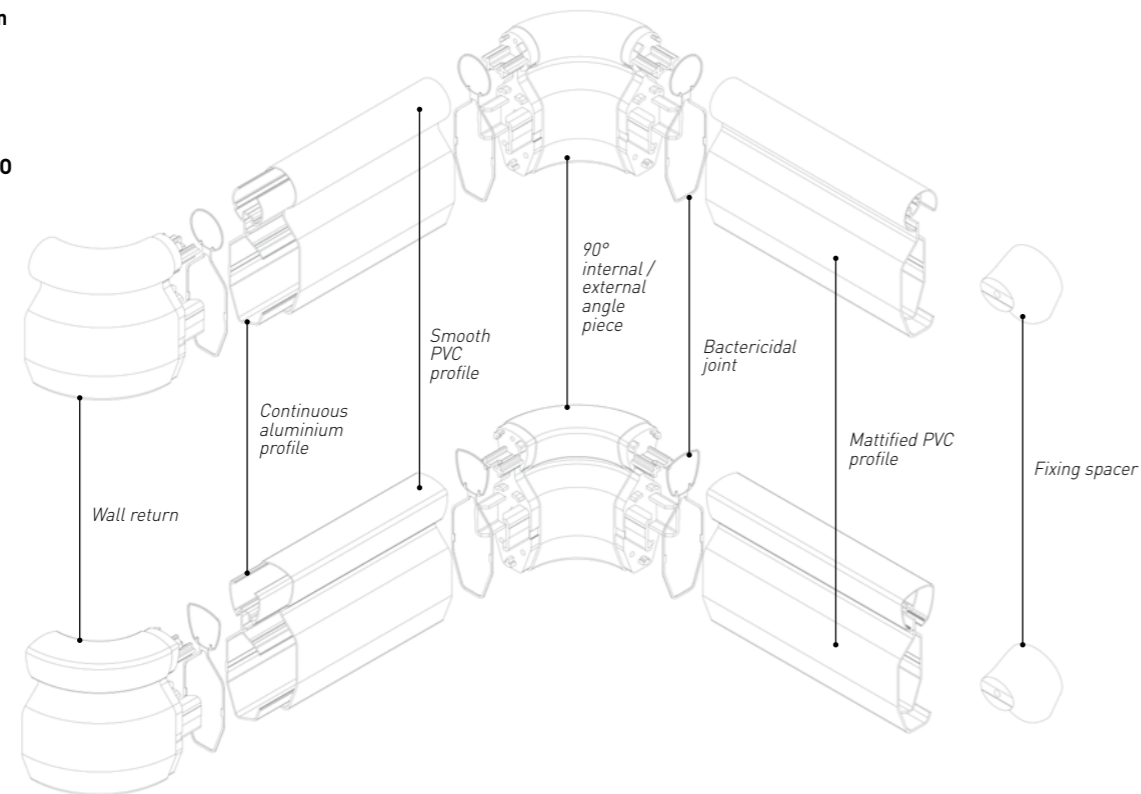

7.2 PREPARING ESCORT'DUO AND LINEA'DUO HANDRAILS

Refer to Sections 3.1 and 3.2 on how to calculate the cutting lengths for the profiles. Once the profiles have been cut to length:

- First drill the holes in the grooved line of the aluminium rail for the fixing spacers near the endcaps and / or wall returns and / or internal / external angle pieces. The distance must not exceed 100 mm. Then drill the holes for the fixing spacers every 800 mm to 1,000 mm depending on the expected level of traffic in the area.

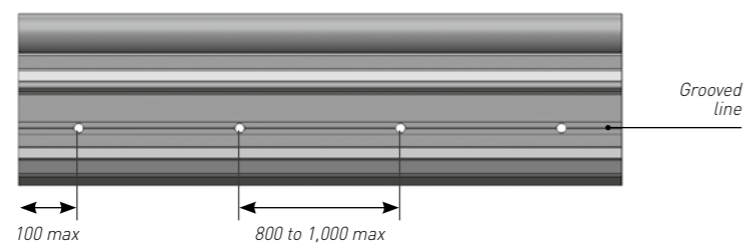

- Fix the endcaps and / or wall returns and / or internal / external angle pieces (make sure that you position the joints) and the aluminium rail with self-tapping screws.

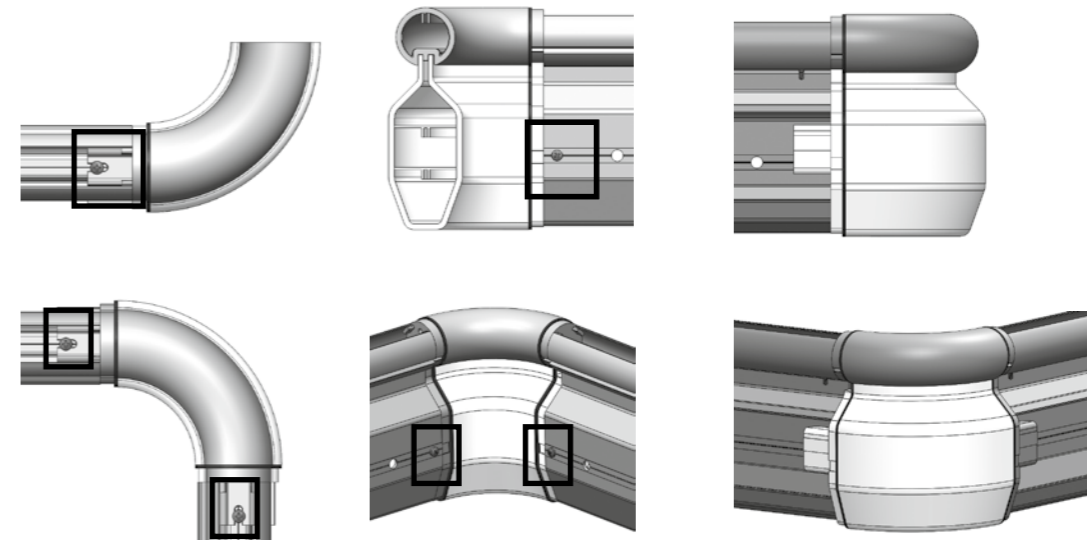

- When joining straight lengths: mark the holes of the joining piece on both profiles (using the piece's outline). Drill the holes (diameter M5) in the grooved line of the aluminium rail and countersink the holes to conceal the screw heads. Assemble the profiles together.

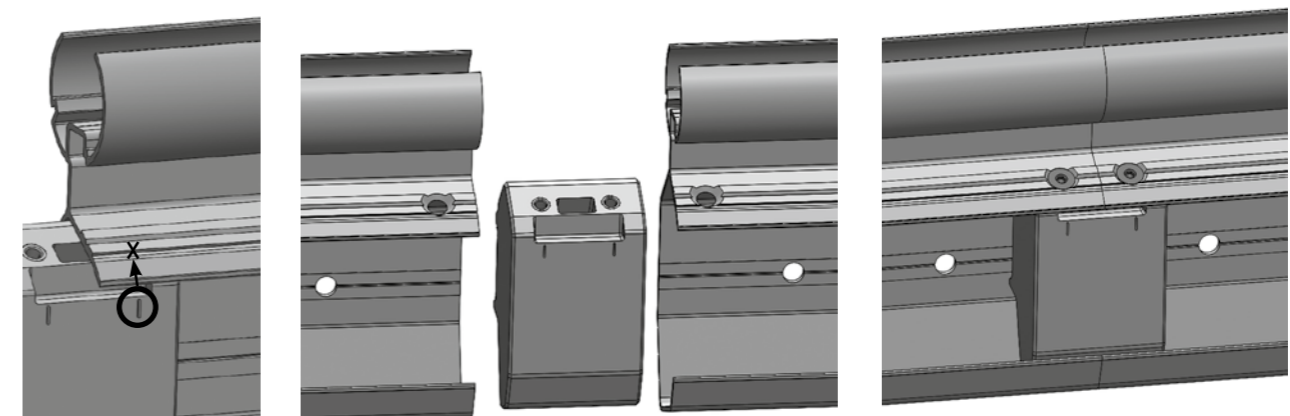

7.3 FIXING ESCORT'DUO AND LINEA'DUO HANDRAILS

- Hold the handrail against the wall, leaving a space of at least 30 mm between the end of the handrail and the edge of the wall. This space means that finishing accessories can be replaced without having to remove the entire handrail.

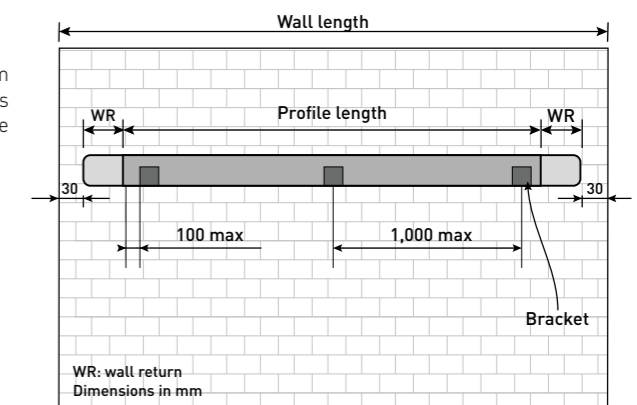

INSTALLING ESCORT'DUO AND LINEA'DUO

- Mark the holes to be drilled for the fixing spacers. For a handrail height of 900 mm (measured at the handrail's upper surface), the drilling height is 800 mm.
- Drill the holes marked on the wall. Insert the plugs.
- Fix the rail with its fixing spacers, starting at each end (the PVC sheaths have not yet been installed as shown in the diagram).

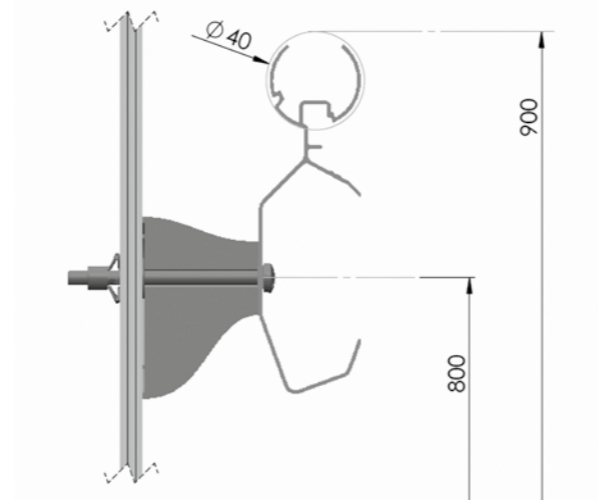

- Clip the "upper" PVC sheath and then the "lower" PVC sheath.

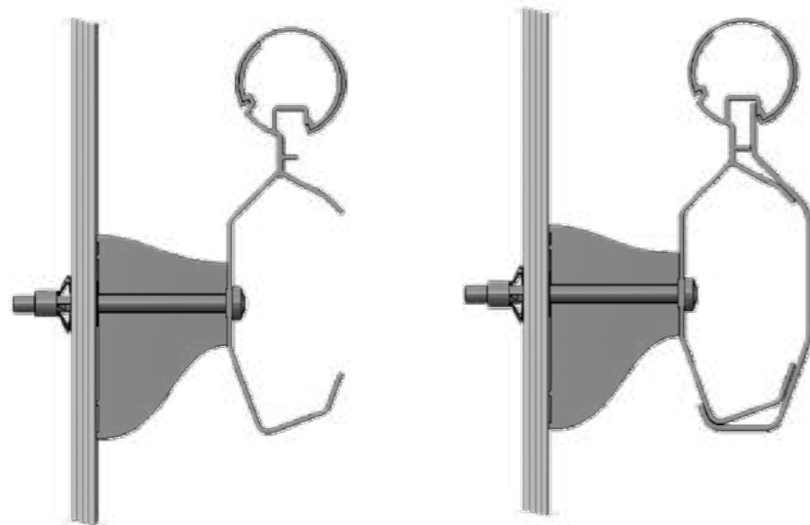

INSTALLING PERFORMER 2

8. PERFORMER 2 HANDRAIL

8.1 PRESENTATION AND ASSEMBLY OF THE DIFFERENT ACCESSORIES FOR PERFORMER 2 HANDRAILS

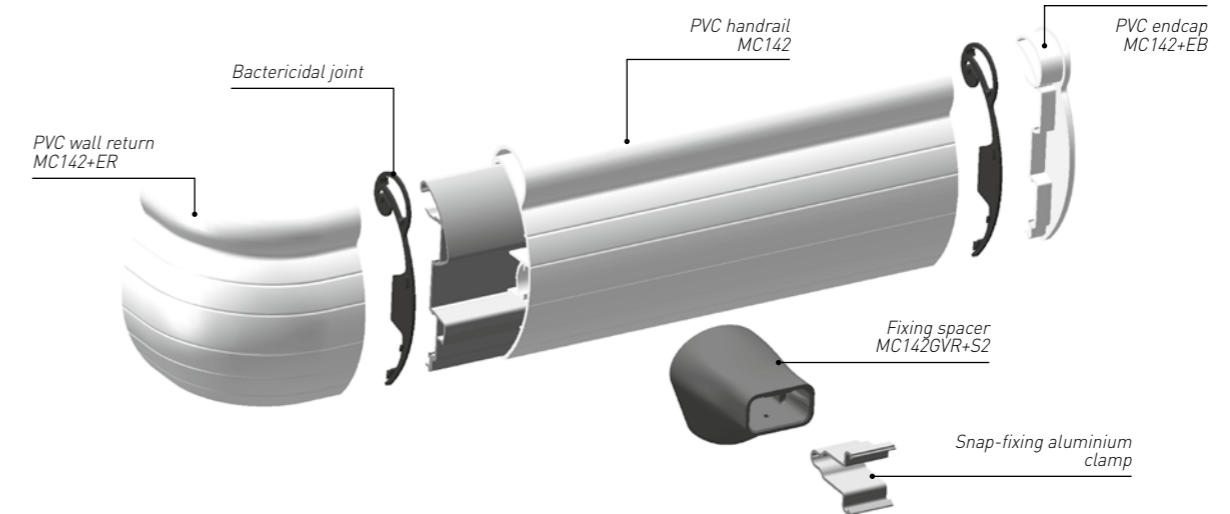

8.2 PREPARING PERFORMER 2 HANDRAIL

Refer to Sections 3.1 and 3.2 on how to calculate the cutting lengths for the profiles. Once the profiles have been cut to length:

If using a wall return:

- Begin by placing the wall return and the bactericidal joint on one side of the aluminium profile.
- Check that the wall return is perpendicular to the aluminium profile before fixing.
- Attach the wall return using a 3 mm self-tapping screw in the aluminium profile.
- The self-tapping screw must be positioned 10 mm from the end of the wall return.

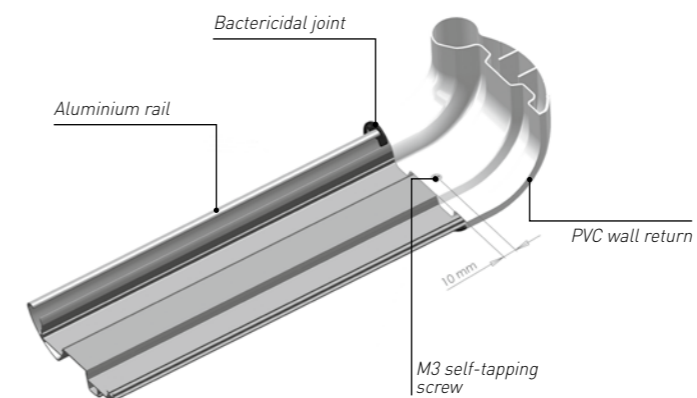

- Clip the PVC profile onto the aluminium rail and slide it against the joint, while making sure that the bosses fit into the slots.
- Ensure that the bosses used to hold the joint in place are properly inserted in the accessory slots.

INSTALLING PERFORMER 2

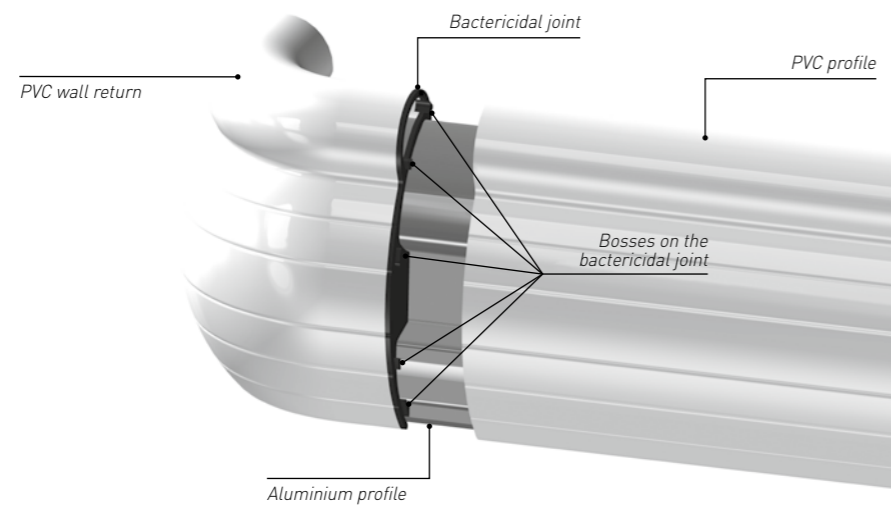

If using an endcap:

- Begin by placing the endcap and the bactericidal joint on one side of the PVC profile.
- Check that the endcap is perpendicular to the PVC profile before fixing.
- Attach the endcap using a 3 mm self-tapping screw in the PVC profile.
- The self-tapping screw must be positioned 5 mm from the edge of the endcap.
- Slide the aluminium rail into the PVC profile.

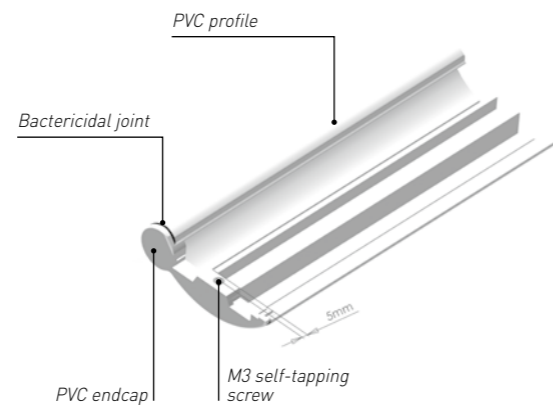

- Ensure that the bosses used to hold the joint in place are properly inserted in the accessory slots.

INSTALLING PERFORMER 2

On the other side of the rail:

- Place the joint and the required accessory (endcap or wall return) on the other side of the rail and fix the accessory (according to the specific procedure for the accessory above).
- Lock the assembly using a self-tapping screw at both ends of the aluminium profile.
- Finally, fit the snap-fixing clamps to the aluminium profile.

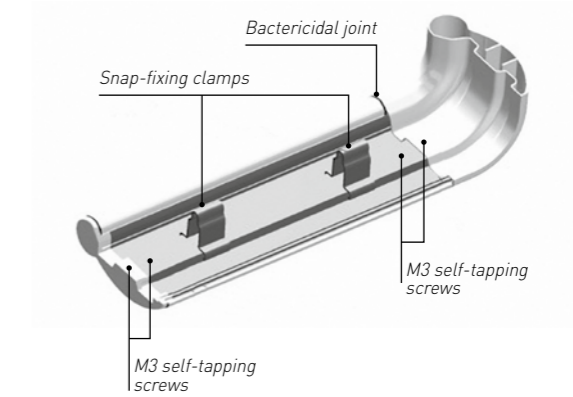

Two lengths of PERFORMER 2 handrails can be joined with a single piece that aligns and secures the joint. The jointing piece is fixed to the aluminium rail with two 5 mm socket screws.

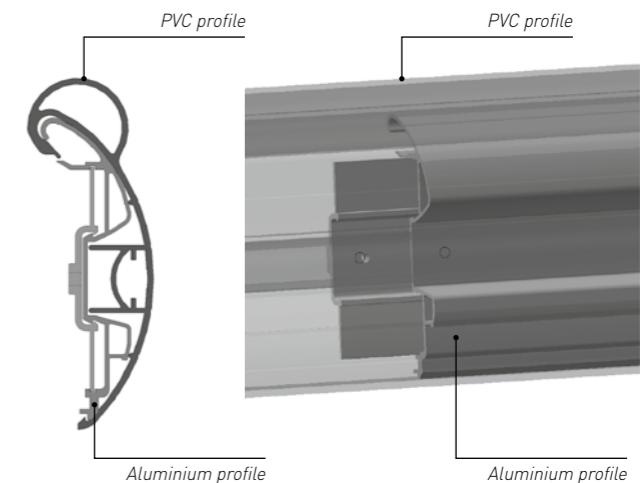

In case of a PERFORMER 2 handrail, offset the ends of the aluminium and PVC profiles to conceal any clearances.

8.3 FIXING PERFORMER 2 HANDRAILS

- For a handrail height of 900 mm above the floor, position the fixing spacers at a height of 822 mm (for MC142GVR+S2 spacers).
- Mark out the wall using a pencil and rule, or a laser.
- Position the outer spacers at 150 mm from the edge of the wall (as close as possible to the wall return).

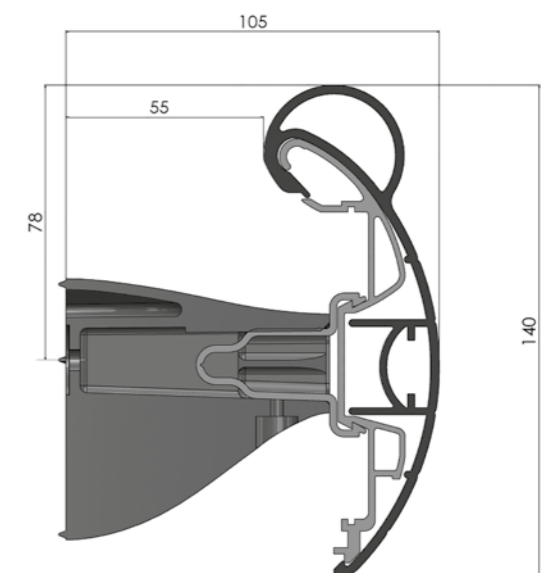

INSTALLING PERFORMER 2

- Drill and plug the wall, hold the spacer against the wall, insert the screw and then tighten.
- Set the spacers every 800 mm (600 mm in heavy-traffic areas).

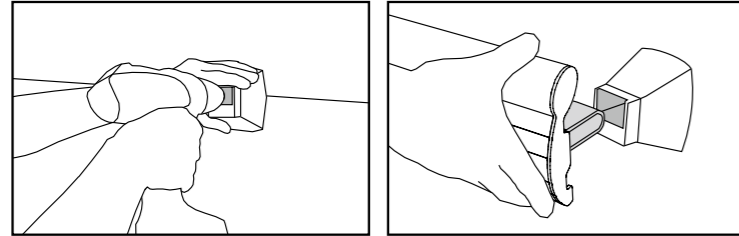

- Insert the snap-fixing clamps in the spacers.
- Adjust the gap between the wall and the handrail as required and secure in place with the self-tapping screw.

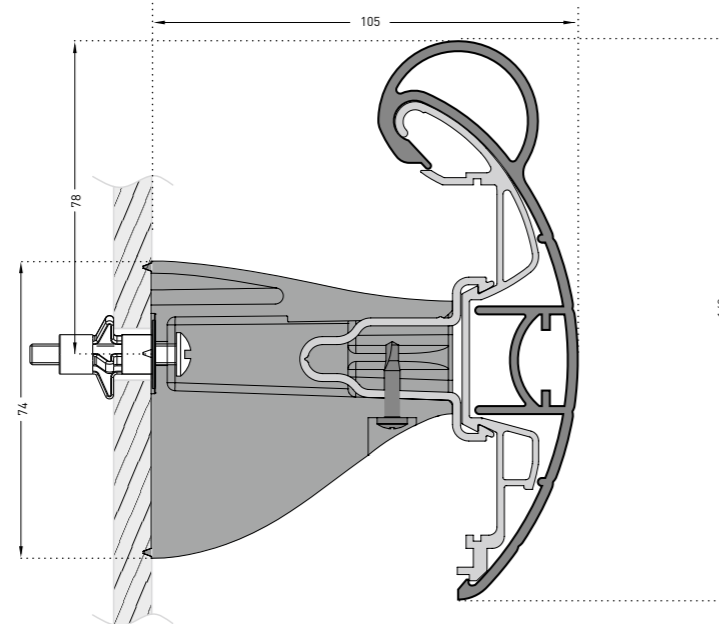
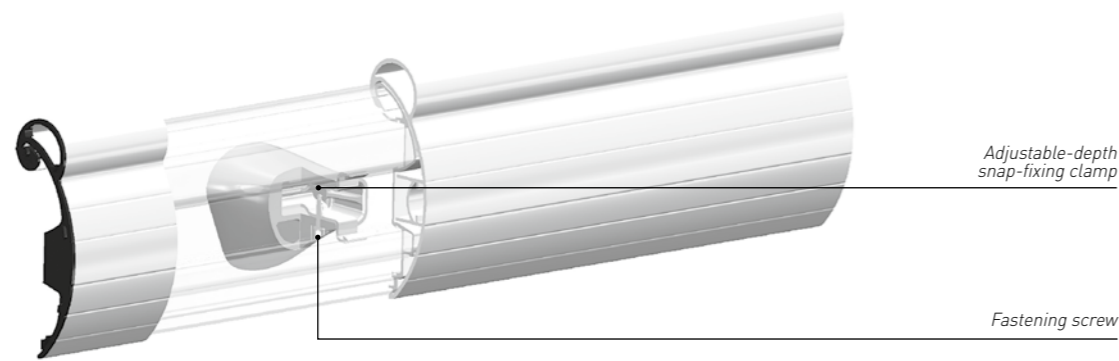

TECHNICAL SOLUTIONS

9. INTERNAL, EXTERNAL AND MADE-TO-MEASURE ANGLE PIECES

Table summarising the angle pieces available for SPM handrails:

HANDRAIL	INTERNAL ANGLE PIECE	EXTERNAL ANGLE PIECE	MADE-TO-MEASURE ANGLE PIECE
ESCORT	Available	Available	Available from 90° to 165°
STARLINE	Available	Available	Available from 90° to 160°
LINEA TOUCH	Available	Available	Available from 90° to 160°
PERFORMER 2	Unavailable	Available	Unavailable
ESCORT DUO AND LINEA DUO	Available	Available	Unavailable

Each angle must be accurately measured beforehand with a compass.

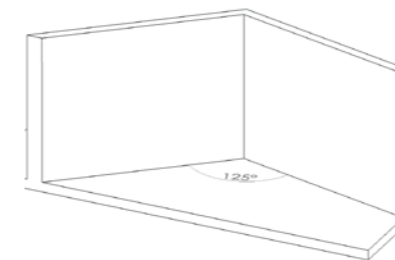

Internal angle of 125°

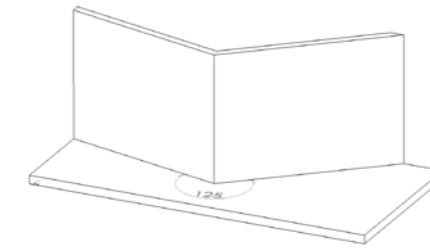

External angle of 125°

You are advised to use the following procedure to obtain a perfect fit between the handrail and the angle piece, while ensuring that the angle piece is centred over the corner of the wall:

- Mount the handrail onto one end of the angle piece and tighten the fixing screw (or drill and pop-riev for STARLINE and PERFORMER 2 handrails).
- At the other end of the angle piece, insert a 500 mm length of handrail. This length will be used as a template and should not be permanently attached to the angle piece.
- Mount the brackets on the handrails (with two brackets on the template).
- On the first wall section, mark out the mounting height for the handrail.
- Position the assembly against the wall over the height marks and then hold the brackets on the template against the opposite wall. This method makes it easier to keep the assembly steady.
- Mark the bracket fixing holes on the wall (using a spirit level to check that the assembly is horizontal).
- Rest the assembly on the ground and remove the template.
- Drill and plug the first wall section (i.e. the handrail side, not the template side).
- Assemble and fix the handrail and its brackets to the angle piece in place of the template.
- Position the assembly against the wall according to the marks drawn on the wall.
- Fix the first section of the handrail to the wall (one person fixes the handrail, starting with the end brackets, while the other person supports the other handrail section to avoid breaking the angle piece).

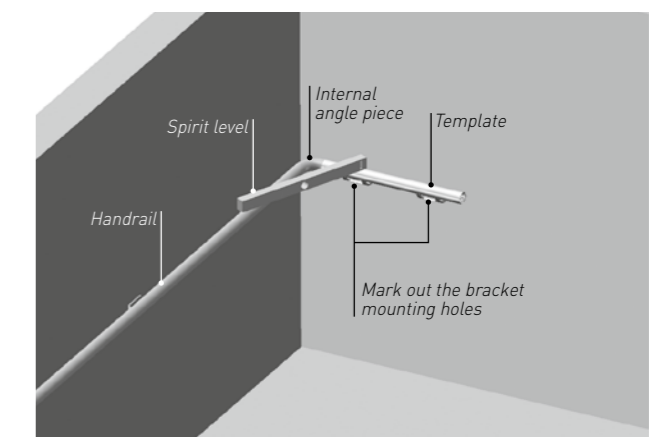

- Mark out the fixing holes for the handrail that has not yet been attached.
- Once the holes have been marked, remove the assembly from the wall by unscrewing the brackets for the handrail fixed earlier.
- Drill and plug the second wall section.
- Reposition the assembly and fix the first handrail section and then the second handrail section onto the wall.

TECHNICAL SOLUTIONS

10. ADJUSTMENT SHIM FOR ESCORT, STARLINE, LINEA'TOUCH AND TOUCH+ HANDRAILS

If the wall surface is uneven, the brackets can be adjusted against the wall using 10 mm thick adjustment shims. These shims are fitted behind the brackets.

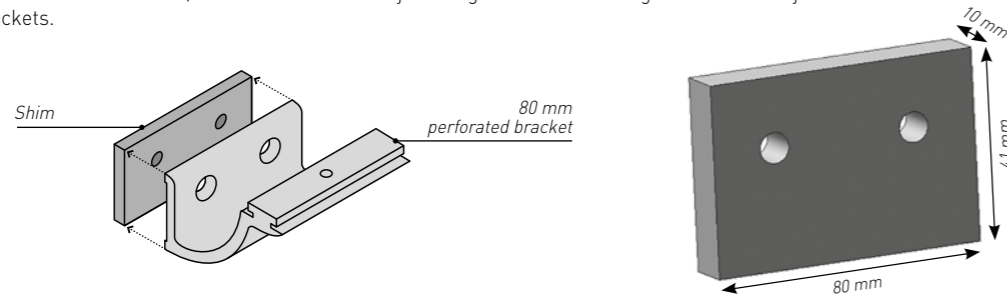

11. LAYING HANDRAILS WITH THE SERVICE DUCT KIT

Where a service duct has been installed, a removable handrail section may be required to provide easier access to the duct.

The distance between the brackets must not exceed 1,200 mm. The handrail must be located in a low-impact area. The strength of the wall fixings must be suited to the forces exerted.

Service duct kit for ESCORT handrails

For ESCORT handrails, the service duct kit is created in-situ (by cutting the profile to the dimensions of the access cover using 45° mitred cuts). If the removable ESCORT handrail section is longer than 1,100 mm, a quick-removable bracket will need to be fitted to the access cover. Quick-removable brackets come with an assembly wedge that can be clamped into the groove in the aluminium rail with a 3 mm Allen key.

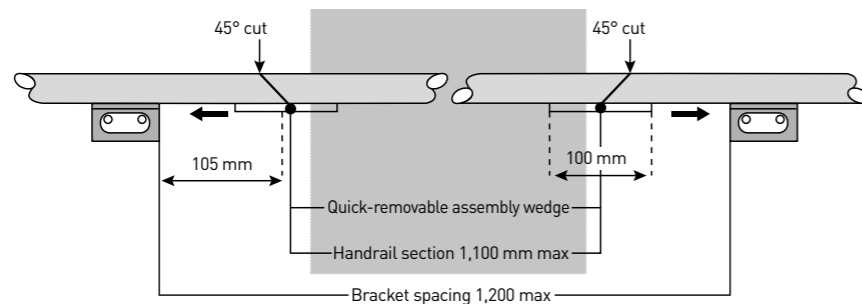

Rapid'Access® articulated link: adaptable angle piece to provide access to service ducts. This accessory replaces the assembly wedge on one of the sides and allows the handrail to be partially removed.

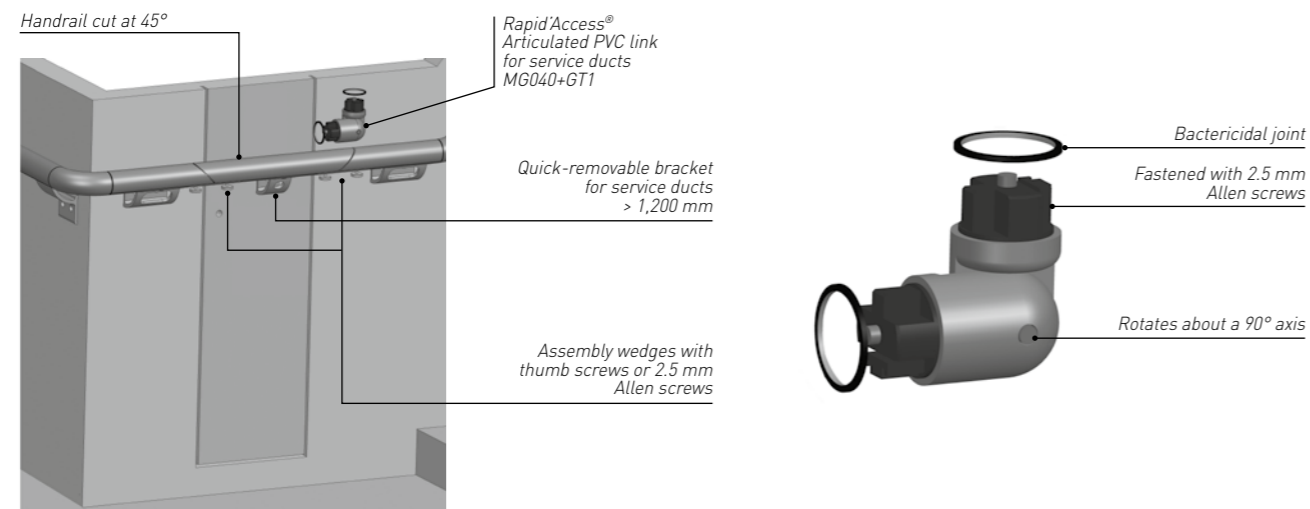

TECHNICAL SOLUTIONS

Service duct kit for LINEA'TOUCH handrails

- The service duct kit is created in-situ by cutting the profiles at 45° and positioning the sliding assembly wedges.
- Where the removable LINEA'TOUCH handrail section is longer than 1,100 mm, a quick-removable bracket will need to be fitted to the access cover.
- Quick-removable brackets come with an assembly wedge that can be clamped into the groove in the aluminium rail with a 2.5 mm Allen key.

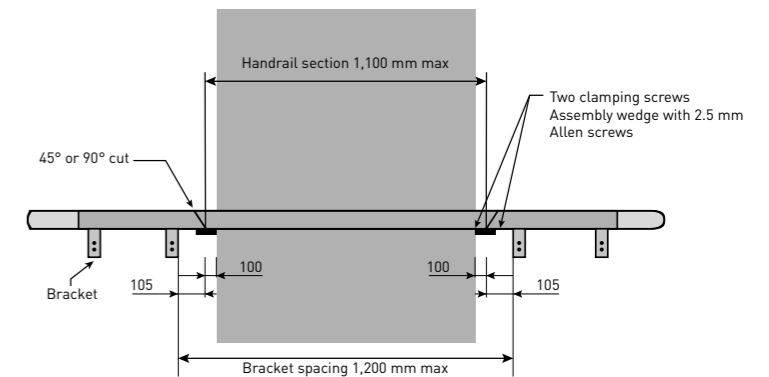

Service duct kit for ESCORT'DUO and LINEA'DUO handrails

The service duct kit is created in-situ by cutting a section of wall protection handrail to the length of the access cover. The cut must be 90°. Then position the elements according to the dimensions shown in the drawing opposite.

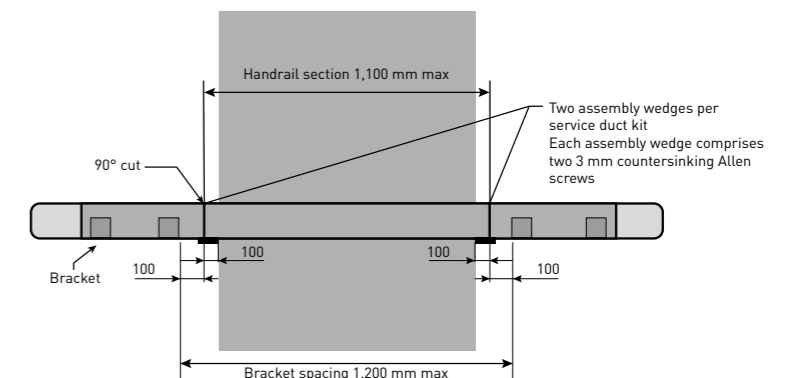

- Mark the holes of the assembly wedges (by using the wedges' outline). Drill the holes (diameter M5) in the grooved line of the aluminium rail and countersink the holes to conceal the screw heads. Assemble the profiles together.

- The upper PVC profile is the same length as the aluminium profile.

- The lower PVC protection rail measures at least 60 mm more than the aluminium profile to allow access to the screws for removal.

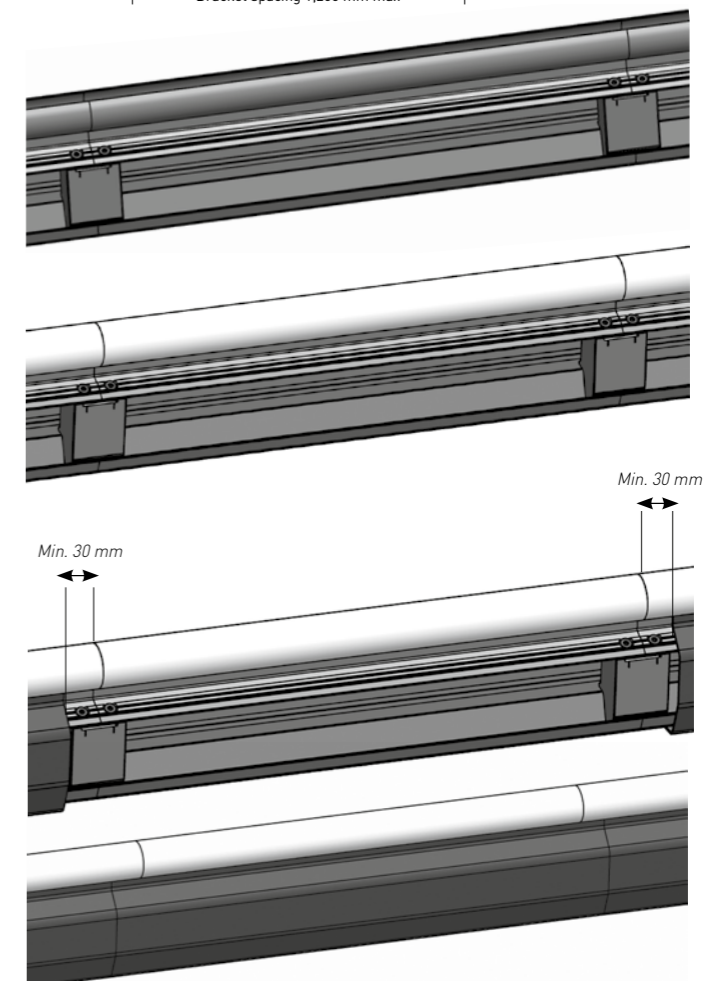

TECHNICAL SOLUTIONS

Service duct kit for STARLINE handrails

For STARLINE handrails, SPM can provide a ready-to-install kit in lengths up to 1,100 mm (other lengths on request).

- Where the removable STARLINE handrail section is longer than 1,100 mm, a quick-removable bracket will need to be fitted to the access cover.
- Quick-removable brackets come with an assembly wedge that can be clamped into the groove in the aluminium rail with a 3 mm Allen key.

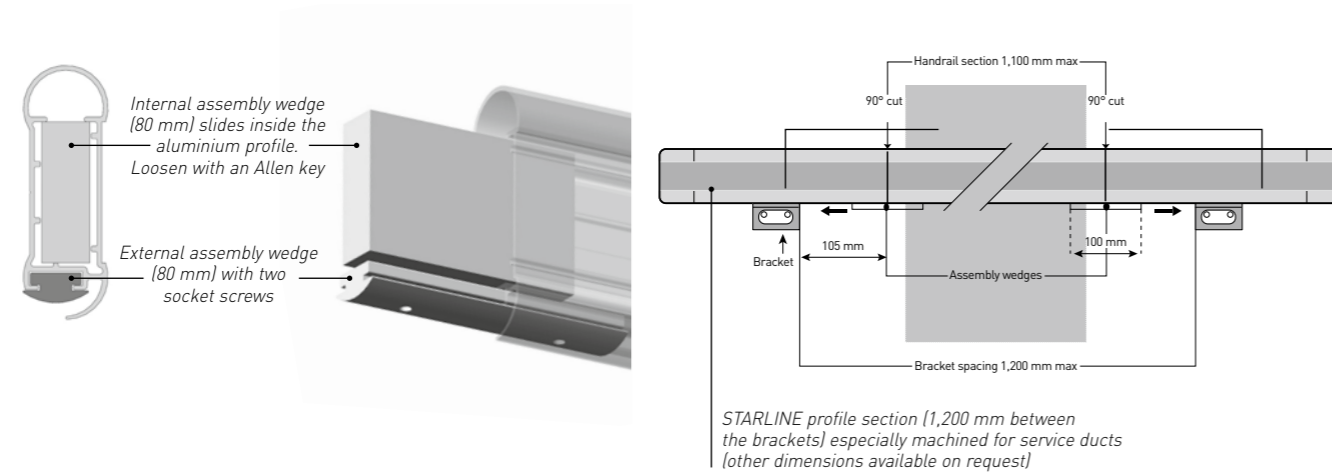

TECHNICAL SOLUTIONS

- When curved handrails are installed in a run with straight handrails, the curved section is terminated with straight lengths at each end to create a perfect junction.

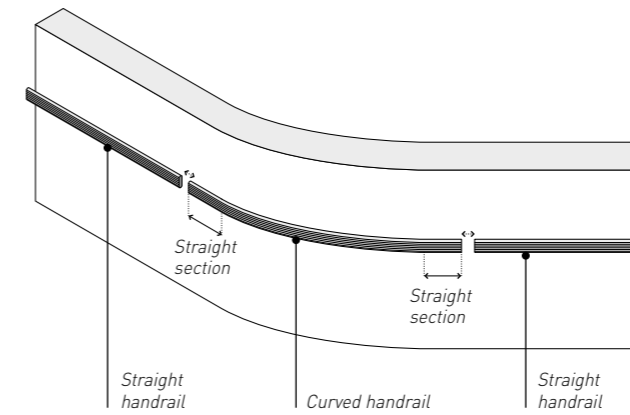

13. MAINTENANCE

- Do not leave products exposed to sunlight. Excessive increases in temperature could lead to changes in colour and/or deform the product.
- The following products are recommended for cleaning:
 - Ammonia
 - Ethanol
 - Isopropyl alcohol
 - Essence F cleaner
 - Standard cleaning products, such as Bioquell and Anios
- Products MUST NOT BE CLEANED with a scouring pad, such as a Scotch-Brite pad.

DO NOT USE:



- White spirit
- Acetone
- Petrol
- Paint thinners

It is essential to use solvents that do not leave any greasy or dry residue. If using non-recommended products, test on an offcut. Reactions may differ depending on the colour of the product and the solvents used.

12. INSTALLING CURVED HANDRAILS

Curved handrails can be installed using **ESCORT, STARLINE, LINEA TOUCH and TOUCH+** handrails.



- Important: for curvature radii below 2 metres, curved handrails are wall-mounted using one of the two brackets below.

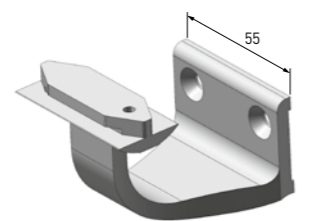

55 mm bugled bracket
-specific curving-
ESCORT and STARLINE
MG040ANO+S3C or MC090ANO+S3C

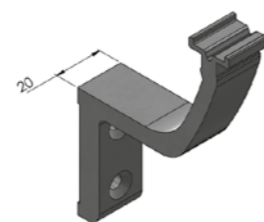

20 mm refined bracket
LINEA TOUCH
ME000ANO+S1

Service Export

Tel : + 33 (0)5 34 39 41 00
Email : export@spm.fr

spm-international.com / follow us



SPM international S.A.S.

16 rue Isabelle Eberhardt
CS 92083 - 31019 Toulouse Cedex 2 -
France
Tel : +33 (0)5 34 39 40 00

**PANELS
HANDRAILS
PROTECTION RAILS
CORNER PROTECTION**

Committed to sustainable development



A company of **Gerflor**

